

AMSOIL[®] BMK26

Ford 7.3L Dual Remote Bypass System Installation and Servicing Instructions

IMPORTANT NOTICE

- Read **ALL** instructions completely.
- Improper installation can result in serious system and/or equipment damage. If you are uncomfortable with the instructions or have questions, **do not attempt installation**. Consult a mechanic or contact AMSOIL Technical Services at (715) 399-TECH for assistance.
- **WARNING:** Extreme care should be taken to avoid bodily harm during installation. Before beginning, ensure engine is cool to avoid burns. Never work in the engine compartment with the engine running. It is advised that you perform a full oil change with installation of this system.

A. BEFORE YOU BEGIN

1. Confirm all items on the Parts List are included in the Kit.
2. Ensure you have the required tools for the job.

RECOMMENDED TOOL LIST

- 1/4" drill bit
- 7/16" wrench
- 7/16" socket
- 1" socket
- 1" wrench (2)
- 1" crow foot adapter
- Center punch
- Hammer
- Adjustable filter wrench
- Torque wrench
- Drain oil pan
- Vice
- Drill
- Utility knife
- Hose cutter
- Proper socket for thread adapter

PARTS LIST

Ford 7.3L Dual Remote Bypass System (BMK26)

Item	Description	Qty.	Part No.
1.	Filter Mount Assembly	1	BK309
2.	1/4"-20 x 1" Hex Bolt Zinc	4	BP23
3.	1/4" Flat Washer Zinc SAE	6	BP21
4.	1/4"-20 Self Locking Nut Zinc	8	BP22
5.	Fitting, 90°, 7/8"-14 to 5/8" JIC	1	BP331
6.	Fitting, Adapter, 7/8"-14 x 5/8" JIC	1	BP289
7.	Fitting, 1/2" Hose, 7/8"-14 JIC	4	BP360
8.	Hose, 1/2" ID	12'	BP350
9.	Adapter, Filter, 4.38" OD	1	BP400
10.	Thread Adapter, 1 1/2"-16	1	BP401
11.	Gasket, 2.80" OD, 2.50" ID, 0.20" Thk.	1	BP197
12.	O-ring, 1 7/8" ID x 0.10 Thk.	1	BP347
13.	Bracket, Filter Mount Assembly, Top	1	BP194
14.	Bracket, Filter Mount Assembly, Bottom	1	BP195
15.	Hex Head Cap Screw Zinc Plate - 1/4"-20 x 1 1/2"	4	BP185
16.	Fender Washer, SS 9/32" ID	4	BP186
17.	Ea [®] Oil Filter	1	EaO26
18.	Ea [®] Bypass Oil Filter	1	EaBP100
	6" Nylon Cable Tie	4	BP46
	Thread Sealant	1	BP198
	BMK Mounting Template-BMK22, 23, 26, 27, 28	1	BP502
	Instruction Sheet	1	BP256

OPTIONAL PARTS (Not Included)

Description	Qty.	Part No.
Assembly, Oil Sample Petcock	1	BK13
Elbow, 90°, 7/8"-14 JIC to 7/8"-14 JIC	1	BK21
Fitting, 45°, 7/8"-14 JIC to 7/8"-14 JIC	1	BK22

*Not required, but available to ease installation.

See www.amsoil.com or contact your AMSOIL Dealer.

B. ATTACHING FILTER MOUNT

1. Survey the engine compartment for possible mounting locations. The mount should be located as close to the existing full-flow filter as possible. Select an area where the filtration system will not be damaged by road debris or off-road travel, and make sure the mounting structure is adequate to carry the weight of the filtration system. Reference Diagram A for an approximation of space required for mounting the system and removing filters. Reference Diagram B for appropriate mounting angles.
2. When the mounting location has been determined, put the provided mounting template sticker in place. Using a center punch and hammer, mark the centers of the drilling locations.
3. Using a 1/4" drill bit, drill the center-punched holes on the template, remove the sticker and attach the BP194 and BP195. Use the 4 - 1" long 1/4" bolts, nuts, small washer and fender washers provided. See assembly Diagram D for details. Use a wrench to hold either the nut or bolt in place; use the socket and torque wrench on the opposite end to tighten to 8 ft-lbs.
4. In the same manner, attach the BK309 to the mounting brackets using 4 - 1 1/2" long 1/4" bolts, nuts and washers provided.

Warning: The bolts **must** be installed so the nuts are on the side opposite the filter nipples. Failure to do this will result in the bolts hitting the oil filters.

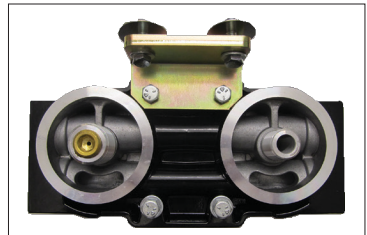

Note: All fittings on the BK309 have been installed to the proper torque. There is no need to make any adjustment to these fittings unless installing a BK13.

C. OIL SUPPLY

- Using an oil drain pan to capture lost oil, remove the existing full-flow engine filter. Clean the gasket seating area on the engine with a lint-free cloth.
- Temporarily thread the BP400 and BP401 onto the engine and determine the direction in which you would like the hoses to intersect the adapter assembly. Installation of the BP289 and BP331 fittings can be performed one of two ways as shown below. Choose the best method to ensure a smooth hose transition to and from the engine. Remove the assembly from the engine.



- Apply thread sealant as noted in Diagram C on the BP289 and BP331. The sealant should be placed on the O-ring-side thread only.

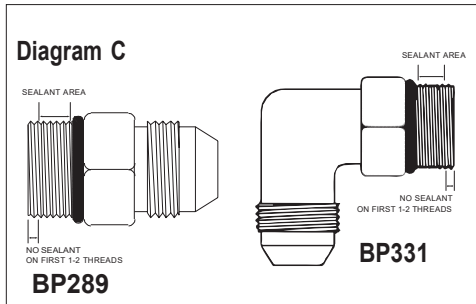

- Lubricate the O-ring of the BP289 and install in the adapter assembly. If installing into the BP401 (as in Option 2), tighten to 85 ft-lbs. If installing into the side of the BP400 (as in Option 1), tighten to 56 ft-lbs.

- Lubricate the O-ring on the BP331 and install in the adapter assembly, turning until the washer contacts the face. Unscrew up to one full turn to point the fitting in the desired direction. Using a wrench to hold the fitting body, use a 1" crow foot wrench to tighten the locking nut to 85 ft-lbs if installing in the BP401 (as in Option 1), or 56 ft-lbs if installing in the side of the BP400 (as in Option 2).
- Apply a thin coat of oil on the spin-on adapter gasket and the adapter nut O-ring.
- Reassemble adapter and install on engine. Make sure fittings are correctly positioned and tighten the adapter assembly onto the engine, first tightening the BP401 to finger-tight, then tightening an additional 1 1/2 turns past finger-tight.

D. OIL FEED AND RETURN LINES

- NOTE:** The hose and hose fittings supplied with this kit are matched to provide maximum performance and life expectancy. Interchanging with other types or brands is not recommended and should be avoided. Should additional hose be required, it may be obtained from AMSOIL by ordering part number BP350 by the foot.
- DO NOT** install oil hoses near hot exhaust parts or near sharp metal components that could cause abrasive wear.
- DO NOT** create sharp bends in oil hoses when installing.

- OIL SUPPLY HOSE,** • Measure the amount of hose (BP350) needed to route from the side port on the spin-on adapter (labeled **A**) to the port with arrow pointing **IN** on the filter mount. • Ensure a minimum bend radius of 2 1/4" is maintained at all corners. Also, bends in hose should not begin at hose fittings.

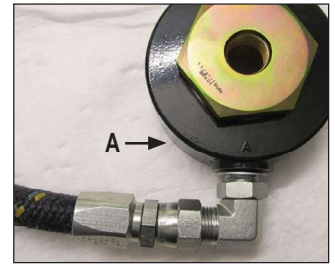

Note: Ensure hose has significant additional length to accommodate movement of engine.

2. HOSE FITTING ASSEMBLY INSTRUCTIONS

- Using a utility knife or hose cutter, squarely cut the hose to the proper length (Step 2a).
- Install BP360 on both ends of the cut hose. Screw nut portion of the fitting **counter-clockwise** onto hose until it bottoms. Back hose out 1/2 turn (Step 2b).

Note: Do not use any form of thread sealant anywhere on the hose fittings (BP360).

- Oil tapered nipple thread areas liberally with oil. You may also oil inside of hose. Do not oil hose cover (Step 2c).
- Screw nipple thread into socket using wrench on nipple hex until nipple hex shoulders against socket (Steps 2d, 2e, 2f).

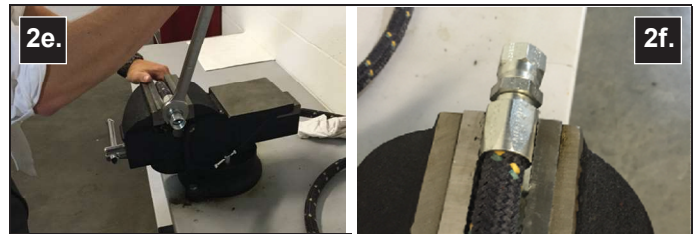

- Route and connect the hose assembly for the oil supply. Run the hose from the side port on the BP400 labeled **A** to the port with the arrow pointing **IN** on the BK309. (BK21 or BK22 may be installed at this time between the hose fitting and mount or spin-on adapter.)

- On both ends tighten the nut finger-tight. Place a mark on the middle of one flat of the nut. Starting from this position, tighten the nut further by 1.5 flats using one wrench to hold the BP289 and the other to turn the nut on the BP360. (A flat is referred to as one side of the hexagonal tube nut and equates to 1/6 of a turn.)

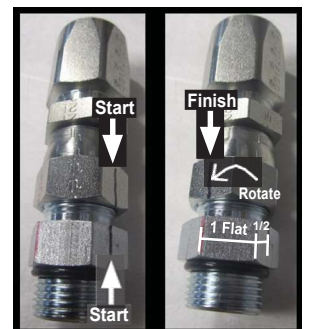

5. **OIL RETURN HOSE**, Repeat Steps D.1 through D.4. Connect hose at the thread adapter port labeled **B** and the port with the arrow pointing **OUT** on the BK309.

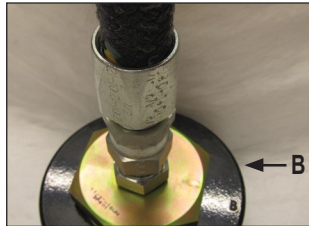

6. Use plastic ties (BP46) to secure hose in position and away from potential damage. Trim ties with side cutter.

Note: Over tightening the plastic ties may cause the hose to collapse and restrict oil flow.

7. Fill the full-flow filter and bypass filter with the same engine oil being used in the vehicle. Lubricate the filter gaskets with oil and spin filters onto mount. Tighten per instructions on the filter.

E. STARTUP PROCEDURES

1. Check that all fittings and hoses are securely attached, and that the hoses are routed properly.

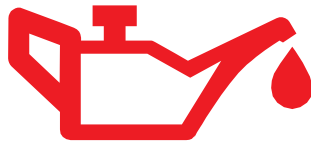

2. Check engine oil level. Fill to full mark on the engine dipstick if necessary.

3. With the equipment secured start the engine and immediately check oil pressure. **Note:** Pressure may initially take a moment or two to rise.

Caution: Carefully check for leaks at fittings, hoses and mount. If leaks are observed, **STOP ENGINE IMMEDIATELY**, repair leaks and continue.

4. After engine has warmed, shut off and re-check engine oil level. Top off as necessary.

5. Record date of installation and equipment operating hours or mileage.

F. PERIODIC MAINTENANCE

1. During the warranty period, annually inspect fittings and hoses. Check for leaks, hose deterioration and cuts. Repair and/or replace as necessary. See the **AMSOIL Limited Warranty – Bypass Filter Systems** at www.amsoil.com for complete information.

2. To change the filter elements:

- a. Ensure engine is off and use caution as the engine, oil and filter may be hot and could result in injury.
- b. Using a filter wrench, remove the filter elements. Dispose of properly.
- c. Clean the filter gasket contact areas on the mount with a clean, lint-free rag.
- d. Lubricate the new filter gaskets with clean oil.
- e. Fill filters as full as possible with engine oil.
- f. Screw on new filters, tighten per instructions on the filter.
- g. Start engine and check for leaks.
- h. Check engine oil level, fill as needed.

3. Record date of installation and equipment operating hours or mileage for future reference.

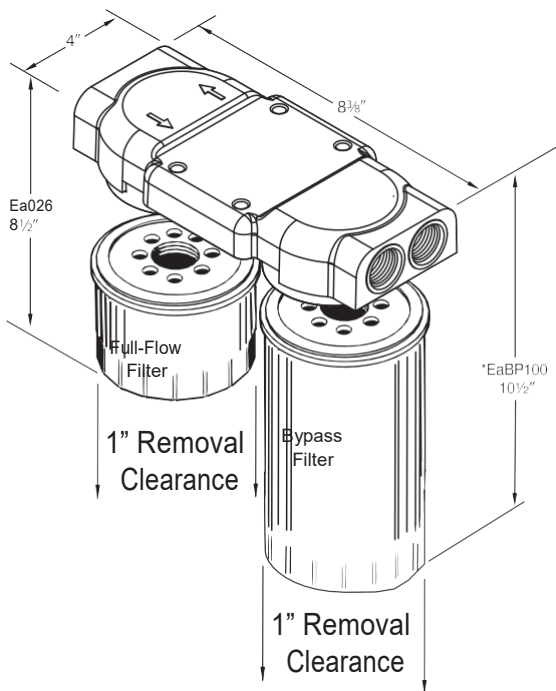
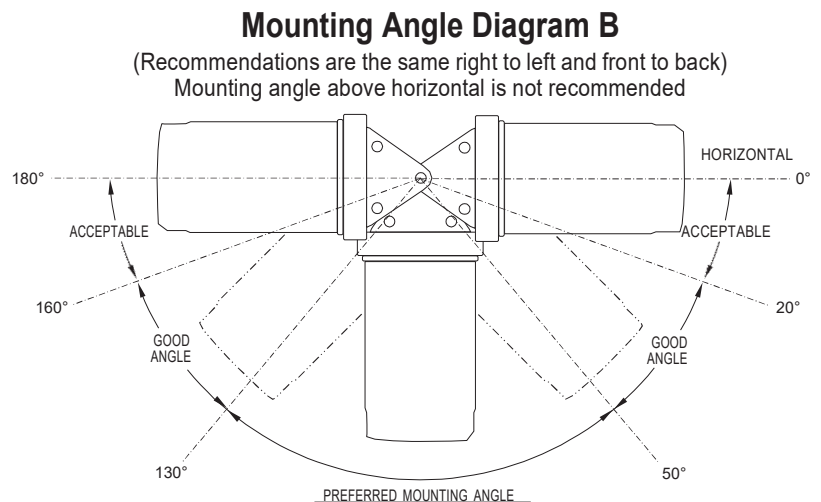

Diagram A

MINIMUM AREA NEEDED FOR DUAL MOUNT AND SPIN-ON OIL FILTER ELEMENTS

* Mount and element heights plus 1-inch removal clearance



Mounting Angle Diagram B

(Recommendations are the same right to left and front to back)
Mounting angle above horizontal is not recommended

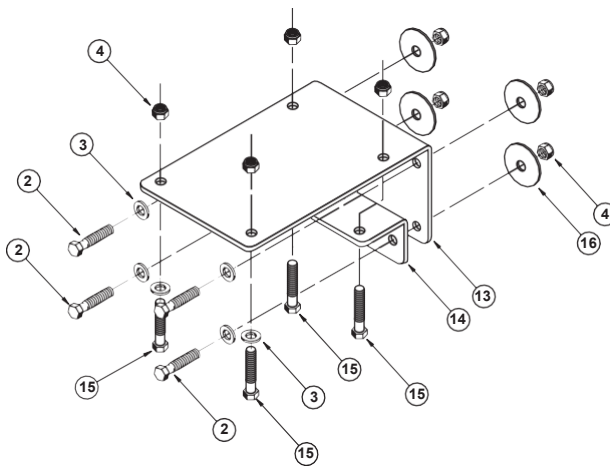
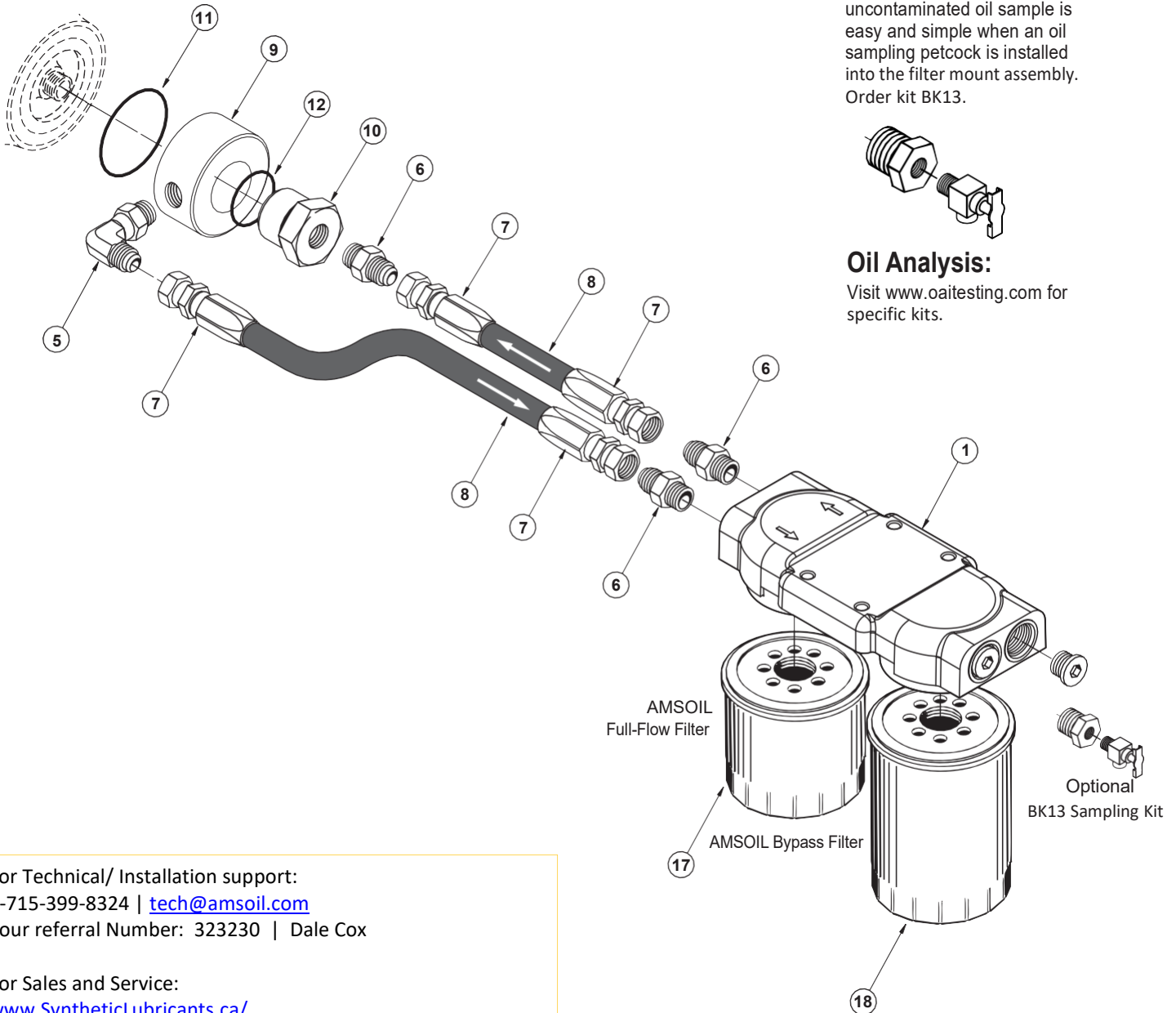
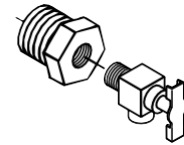

Diagram D



INSTALLING AN OIL SAMPLING PETCOCK ON THE SPIN-ON BYPASS:

Getting a clean and uncontaminated oil sample is easy and simple when an oil sampling petcock is installed into the filter mount assembly. Order kit BK13.



Oil Analysis:

Visit www.oaitesting.com for specific kits.

For Technical/ Installation support:
 1-715-399-8324 | tech@amsoil.com
 Your referral Number: 323230 | Dale Cox

For Sales and Service:
www.SyntheticLubricants.ca/
 1-613-867-4349 | DaleCox@SyntheticLubricants.ca