

# AMSOIL<sup>®</sup> BMK22

## DUAL-GARD Bypass System Installation and Servicing Instructions

### IMPORTANT NOTICE

- Read **ALL** instructions completely.
- Improper installation can result in serious system and/or equipment damage. If you are uncomfortable with the instructions or have questions, **do not attempt installation**. Consult a mechanic or contact AMSOIL Technical Services at (715) 399-TECH for assistance.
- **WARNING:** Extreme care should be taken to avoid bodily harm during installation. Before beginning, ensure engine is cool to avoid burns. Never work in the engine compartment with the engine running. It is advised that you perform a full oil change with installation of this system.

### A. BEFORE YOU BEGIN

1. Confirm all items on the Parts List are included in the Kit.
2. Ensure you have the required tools for the job.

### RECOMMENDED TOOL LIST

- |                  |                |                 |                            |
|------------------|----------------|-----------------|----------------------------|
| • 1/4" drill bit | • 9/16" wrench | • Hammer        | • Utility knife            |
| • 3/8" drill bit | • 7/8" wrench  | • Torque wrench | • Adjustable filter wrench |
| • 7/16" wrench   | • 1" wrench    | • Drill         |                            |
| • 7/16" socket   | • Center punch | • Hose cutter   |                            |

### PARTS LIST

#### DUAL-GARD Bypass Filter Mounting Kit (BMK22)

Item	Description	Qty.	Part No.
1.	Filter Mount Assembly	1	BK393
2.	1/4"-20 x 1" Hex Bolts Zinc	4	BP23
3.	1/4" Flat Washer Zinc SAE	6	BP21
4.	1/4"-20 Self Locking Nuts Zinc	8	BP22
5.	Bracket, Filter Mount Assembly, Top	1	BP194
6.	Bracket, Filter Mount Assembly, Bottom	1	BP195
7.	1/4"-20 x 1 1/2" Hex Head Bolt	4	BP185
8.	1/4" I.D. Fender Washer	4	BP186
9.	Fitting, 1/4" Hose, 7/16"-20 JIC	4	BP261
10.	Hose 1/4" I.D.	15'	BP251
11.	Fitting, 1/8" NPT to 7/16"-20 JIC	2	BP208
12.	Filter Elements (sold separately)		
	5.78" long filter element	1	EaBP90
	7.25" long filter element	1	EaBP100
	10.44" long filter element	1	EaBP110
	Thread Sealant	1	BP198
	BMK Mounting Template- BMK22, 23, 26, 27, 28	1	BP502
	Instruction Sheet	1	BP274

### OPTIONAL PARTS (Not Included)\*

Item	Description	Qty.	Part No.
13.	Assembly, Oil Sample Petcock	1	BK13
14.	Fitting, Street Tee, 1/8" NPT	1	BP33
15.	Fitting, Street Elbow, 1/8" NPT	1	BP52
16.	Washer, Sealing, hollow bolt	1	BP41
17.	Fitting, Self-tapping hollow bolt	1	BP40
18.	Assembly, Filler Cap Return Fitting	1	BP89

\*Not required, but available to ease installation.  
See [www.amsoil.com](http://www.amsoil.com) or contact your AMSOIL Dealer.

### B. FILTER SELECTION

Any AMSOIL Spin-On Bypass Oil Filter elements may be used with this mount. Select the element size according to your vehicle's oil capacity.

Vehicle Oil Capacity	Recommended Element
15 to 18 quarts	(2) EaBP90
15 to 30 quarts	(2) EaBP100
15 to 42 quarts	(2) EaBP110

Service recommendations for these filters are listed later in these instructions. Selecting a larger filter than recommended will extend the service interval, while selecting a smaller filter than recommended will shorten the service interval.

### C. ATTACHING FILTER MOUNT

1. Survey the engine compartment for possible mounting locations. Select an area where the filtration system will not be damaged by road debris or off-road travel, and make sure the mounting structure is adequate to carry the weight of the filtration system. Reference Diagram A for an approximation of space required for mounting the system and removing filters. Reference Diagram B for appropriate mounting angles.
2. When the mounting location has been determined, put the provided mounting template sticker in place. Using a center punch and hammer, mark the centers of the drilling locations.
3. Drill the previously marked mounting holes and remove the mounting template, then attach the BP194 and BP195. Use the 4 - 1" long 1/4" bolts, nuts, small washer and fender washers provided. Note assembly Diagram D for details. Use a wrench to hold either the nut or the bolt in place; use the socket and torque wrench on the opposite end to tighten to 8 ft-lbs.
4. In the same manner, attach the BK393 using 4-1 1/2" long 1/4" bolts, nuts and washers provided.

**Warning:** The bolts **must be** installed so that the nuts are on the side opposite the filter nipples. Failure to do this will result in the bolts hitting the oil filters.

**Note:** All fittings on the BK393 have been installed to the proper torque. There is no need to make any adjustment to these fittings unless installing a BK13.



### D. OIL SUPPLY

There are two options to draw oil from your application and feed your bypass oil filtration system. *Option One:* Use the port for the oil pressure sending unit.

1. Remove the existing oil pressure sending unit and install the BP33 using thread sealant as noted in Diagram C, tightening 2-3 turns beyond finger-tight. Then re-install the sending unit in one port of the BP33.
2. Using the remaining port of the BP33, install the BP208, using thread sealant as noted in Diagram C, tightening 2-3 turns beyond finger-tight. (Keep in mind the direction you wish the hose to intersect; use the BP52 if necessary.)

**Option Two:** Find one of the usable oil pressure sources which are available on many engine blocks. Openings can be found on the side of the block and near the existing oil filter(s). Make sure the chosen opening is an oil pressure opening by consulting the engine manufacturer. If that option is not available, remove the plug and replace with a pressure gauge. Turn the engine over noting any increase in oil pressure. **DO NOT START ENGINE WITH THE PLUG REMOVED OR A MEANS TO CONTROL OIL PRESSURE.**

1. Install the BP208 using thread sealant as noted in Diagram C, tightening 2-3 turns beyond finger-tight, in the oil pressure opening. (If the BP208 does not fit your oil pressure opening, install a fitting [purchase separately] that will work with your application and connect to the 1/8" NPT of the BP208.)

## E. OIL FEED AND RETURN LINES

- **NOTE:** The hose and hose fittings supplied with this kit are matched to provide maximum performance and life expectancy. Should additional hose be required, it may be obtained from AMSOIL by ordering part number BP251 by the foot.
- **DO NOT** install oil hoses near hot exhaust parts or near sharp metal components that could cause abrasive wear.
- **DO NOT** create sharp bends in oil hoses when installing.

1. **OIL SUPPLY HOSE:** Measure the amount of BP251 needed to run from your oil feed location with the previously installed BP208, to the BK393 port with the arrow pointing **IN**. Ensure a minimum 3/4" bend radius is maintained at all corners. Also, bends in the hose should not begin at the hose fittings.

**Note:** Ensure hose has significant additional length to accommodate movement of engine.

## 2. HOSE FITTING ASSEMBLY INSTRUCTIONS

- a. Using a utility knife or hose cutter, squarely cut the hose to the proper length (Step 2a).
- b. Install BP261 on both ends of the cut hose. Screw nut portion of the fitting **counter-clockwise** onto hose until it bottoms. Back hose out 1/2 turn (Step 2b).

**Note:** Do not use any form of thread sealant anywhere on the hose fittings (BP261).

- c. Oil tapered nipple thread areas liberally with oil. You may also oil inside of hose. Do not oil hose cover (Step 2c).
- d. Screw nipple thread into socket using wrench on nipple hex until nipple hex shoulders against socket (Steps 2d, 2e, 2f).

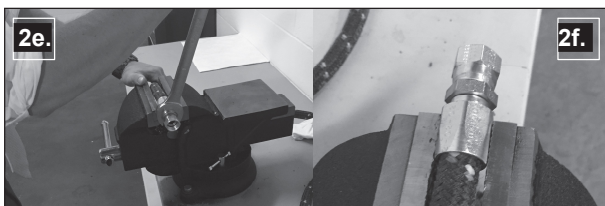
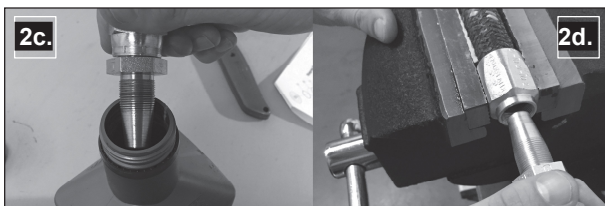

3. Route and connect the hose assembly for the oil supply. Route the hose from BP208 at the oil pressure feed location to the fitting on the BK393 port with the arrow pointing **IN**.

4. On both ends of the hose assembly, tighten the nut of the BP261 finger-tight. Place a mark on the ridge between two flats. Starting from this position, tighten the nut further by two flats using one wrench to hold the BP208 and the other to turn the nut on the BP261. (A flat is referred to as one side of the hexagonal tube nut and equates to 1/6 of a turn.)

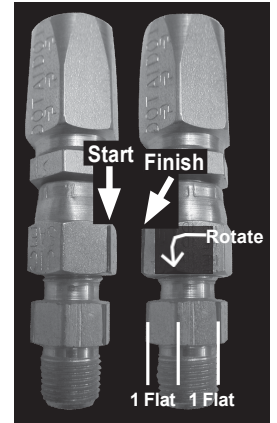

## F. OIL RETURN

1. **Existing Port Options:** Most engines have oil return openings in the crankcase wall or oil pan, usually on the same side as the oil channel pressure opening, but somewhat lower. Remove the plug and determine that it is not a pressurized port and that it offers an unrestricted flow to the oil pan.
  - a. Install the BP208 using thread sealant as noted in Diagram C, tightening 2-3 turns beyond finger-tight, in the oil return opening. (If the BP208 does not fit your oil return opening, install a fitting [purchase separately] that will work with your application and connect to the 1/8" NPT of the BP208.)
2. **New Port Options:** Should your engine not have available openings to return oil, new ports can be created to return the oil to the system. Two primary options exist to create viable return ports: the self-tapping hollow bolt (BP40) and the filler cap return fitting (BP89).

**Note:** The self-tapping hollow bolt should be used on stamped metal components only.

- a. **Using the BP40**
- b. **For oil pan installation:** mark a spot approximately 3" above the bottom of the pan. Avoid any pan formations that may suggest an internal obstruction. For the valve cover, choose a mounting location that will not interfere with the movement of internal components and away from the crankcase ventilation lines.
- c. Using a center punch and hammer, punch a hole in the chosen location between 1/4" (.25") and 5/16" (.3125") in diameter.

**Note:** Do not drill this hole as metal filings are likely to enter the engine.

- d. Using a 9/16" wrench, thread in the self-tapping hollow bolt (BP40) and sealing gasket (BP41). As the bolt is tightened, make sure sealing gasket is snug all the way around the bolt. Tighten bolt to 6-8 ft-lbs.
- e. Install BP208 into BP40 using thread sealant as noted in Diagram C, tightening 2-3 turns beyond finger-tight. Attach and route hose, connecting to the filter mount port marked with the arrow pointing **OUT**. Connect the hose as noted in E.4.

### a. Using the BP89

• **NOTE:** Installation requires drilling that will produce metal and plastic fragments. Be sure these fragments do not get into the lubrication system. It is recommended to remove the fill cap from the engine before drilling. Before returning, clean the part thoroughly to remove all debris.

b. Remove the existing oil filler cap. Be sure there is not a PCV pick-up in this area.

c. In the center of the cap, drill a 3/8" hole.

d. Install the long threaded portion of the optional return line swivel fitting (BP89) into the top of the oil filler cap. Secure with the provided self-locking nut and 9/16" wrench.

e. Using either a cut-off wheel or saw blade, trim BP89 threaded portion within 0.25" of self-locking nut. Ensure all debris from trimming is cleaned from BP89 and filler cap, and ensure hole through BP89 was not compromised during trimming operation.

f. Install a fitting adapter (BP208) into the return line swivel fitting with thread sealant as noted in Diagram C. Tighten 2-3 turns beyond finger-tight. Reinstall oil filler cap on vehicle. A 90° Elbow (BP52) may also be used to ease hose routing installation.

g. Attach and route hose, connecting to the filter mount port marked with the arrow pointing **OUT**. Connect the hose as noted in E.4.

3. Fill the selected bypass filters with the same engine oil being used in the vehicle. Lubricate the filter gaskets with oil and spin filters onto mount. Tighten per instructions on the filter.

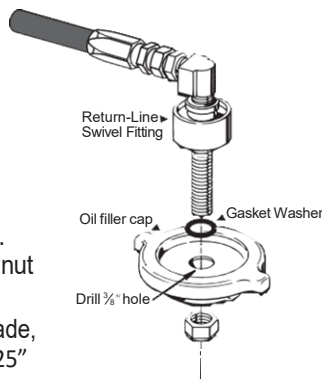

### G. STARTUP PROCEDURES

1. Check that all fittings and hoses are securely attached, and that the hoses are routed properly.
2. Check engine oil level. Fill to full mark on engine dipstick if necessary.
3. With the equipment secured start the engine and immediately check oil pressure. **Note:** Pressure may initially take a moment or two to rise.

**Caution:** Carefully check for leaks at fittings, hoses and mount. If leaks are observed, **STOP ENGINE IMMEDIATELY**, repair leaks and continue.

4. After engine has warmed, shut off and re-check engine oil level. Fill as necessary.
5. Record vehicle mileage/operating hours and date of installation.

### H. PERIODIC MAINTENANCE

1. During the warranty period, annually inspect the fittings and hoses. Check for leaks, hose deterioration and cuts. Repair and/or replace as necessary. See the AMSOIL Limited Warranty – Bypass Filter Systems at [www.amsoil.com](http://www.amsoil.com) for complete information.
2. To change the filter elements:
  - a. Ensure engine is off and use caution as the engine, oil and filters may be hot and could result in an injury.
  - b. Using a filter wrench, remove the filter elements. Dispose of properly.
  - c. Clean the filter gasket contact areas on the mount with a clean lint free rag.
  - d. Lubricate the new filter gaskets with clean oil.
  - e. Fill filters as full as possible with engine oil.
  - f. Screw on new filters, tighten per instructions on the filter.
  - g. Start engine and check for leaks.
  - h. Check engine oil level; fill as needed.
  - i. Record date of installation and equipment operating hours or mileage for future reference.

### Diagram A

MINIMUM AREA NEEDED FOR DUAL MOUNT AND SPIN-ON OIL FILTER ELEMENTS

\* Mount and element heights plus 1-inch removal clearance

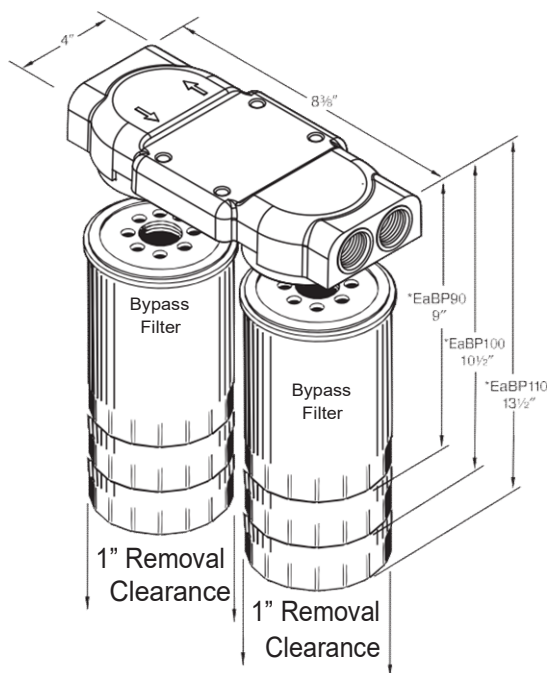

### Mounting Angle Diagram B

(Recommendations are the same right to left and front to back)  
Mounting angle above horizontal is not recommended

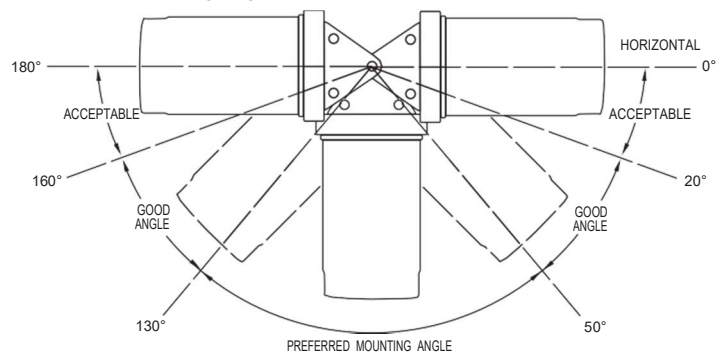

### Diagram C

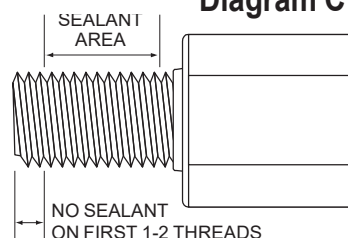

# Diagram D

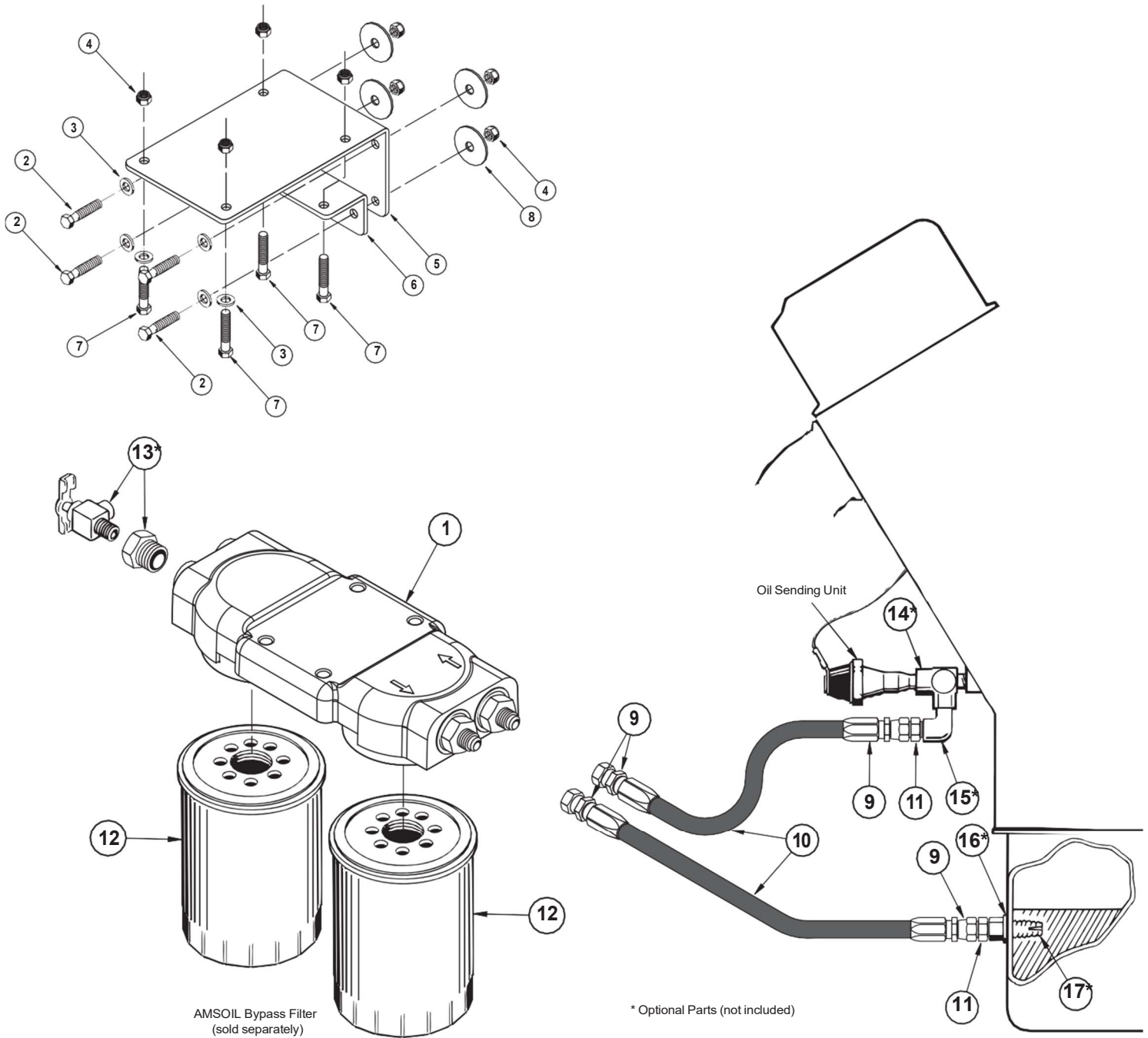

For Technical/ Installation support: 1-715-399-8324 | [tech@amsoil.com](mailto:tech@amsoil.com)

Your referral Number: 323230 | Dale Cox

For Sales and Service:  
[www.SyntheticLubricants.ca/](http://www.SyntheticLubricants.ca/)  
 1-613-867-4349 | [DaleCox@SyntheticLubricants.ca](mailto:DaleCox@SyntheticLubricants.ca)